

# Water Cooled Heat Exchanger for Torque-Arm® Shaft Mounted Speed Reducers and Maxum® Concentric Speed Reducers

## Installation Manual

These instructions must be read thoroughly before installation or operation. This instruction manual was accurate at the time of printing. Please see [dodgeindustrial.com](http://dodgeindustrial.com) for updated instruction manuals.

### PUMP INSTALLATION

Assemble motor (2) and pump (3) using adapter kit (4). Located the pump between the reducer and cooler in any convenient location with the outlet port pointed toward the cooler, using the mounting flange of the motor to secure it. End user must supply motor mounting hardware. Do not force or hammer the pump when installing.

### COOLER INSTALLATION

Locate cooler on pump side of reducer in any convenient location, using the mounting brackets to secure it. End user must supply cooler mounting hardware.

### PIPE FITTING INSTALLATION

#### REDUCER

Remove the drain plug and drain oil from reducer. Remove the necessary pipe plugs. The breather must be installed in the topmost hole - see installation instruction manual for reducer. At reduction drain location, end user must supply hardware to adapt to 3/4 NPT male connection. This is not necessary for Torque-Arm sizes 7 through 15. Drain hole and all other pipe-tapped holes in reducer housing are:

**WARNING: Because of the possible danger to person(s) or property from accidents which may result from the improper use of products, it is important that correct procedures be followed. Products must be used in accordance with the engineering information specified in the catalog. Proper installation, maintenance and operation procedures must be observed. The instructions in the instruction manuals must be followed. Inspections should be made as necessary to assure safe operation under prevailing conditions. Proper guards and other suitable safety devices or procedures as may be desirable or as may be specified in safety codes should be provided, and are neither provided by Dodge® nor are the responsibility of Dodge. This unit and its associated equipment must be installed, adjusted and maintained by qualified personnel who are familiar with the construction and operation of all equipment in the system and the potential hazards involved. When risk to persons or property may be involved, a holding device must be an integral part of the driven equipment beyond the speed reducer output shaft.**

NPSF Tap (inches)	Reducer	Sizes
3/8	Torque-Arm	1 - 4
1/2	Torque-Arm	5 & 6
3/4	Torque-Arm	7 - 15
3/8	Maxum	1 - 4
1/2	Maxum	5 & 6
1	Maxum	7 - 12

Thread 3/4 NPT x 3" pip nipple (7) into adapter. Thread strainer (8) onto 3/4 NPT pipe nipple. Thread another 3/4 NPT pipe nipple (7) into opposite end of strainer. Thread 1" x 3/4 bell adapter (6) onto 3/4 NPT pipe nipple. At oil return location, customer must supply hardware to adapt to 1/2 NPT male connection. This is not necessary for Torque-Arm or Maxum sizes 5 and 6.

#### PUMP

Thread 1/2 NPT street elbow (11) into the oil inlet and outlet ports on the pump inlet port. Thread 1 x 1/2 bell adapter (9) onto 1/2 NPT x 3" pipe nipple.

### HOSE INSTALLATION

Use the 1" hose (5) to connect the reducer drain fitting (6) with the pump inlet port fitting (9). Use a 1/2" hose (12) to connect the pump outlet port fitting (11) with the cooler inlet port. Use a 1/2" hose (12) to connect the cooler outlet port with the oil return adapter fitting in the reducer housing. If the hoses are too long, trim the hoses to an appropriate length and re-attach the hose fittings.

### WATER LINE INSTALLATION

Water inlet and outlet ports of collar are 1" NPT tap. Water lines and fitting are not supplied by Dodge. The installation of suitable water lines is the responsibility of the customer. However, the following suggestions are offered:

- Each water line should be connected to the cooler by a length of flexible hose. The flexible hose is necessary.
- A shutoff valve should be located in the water line above the cooler to control the amount of water entering the cooler.
- The water should flow in the opposite direction to the oil flow through the cooler to obtain the maximum cooling capacity.

## OPERATION

1. Fill the reducer with oil to the proper level. Start the cooling system and allow to run for several minutes. Stop the cooling system and check the reducer oil level. Fill reducer to proper level to replace oil quantity displaced by cooling package.
2. The water flow should be controlled so the reducer does not exceed 200°F.
3. In freezing weather, customary precautions should be taken to prevent freeze-up damage.
4. Unscrew the pipe plug in the bottom of the oil strainer periodically for easy cleaning of sediment and to drain oil from the reducer. Unscrewing the plug into which the pipe plug fits permits removing the strainer screen if desired.

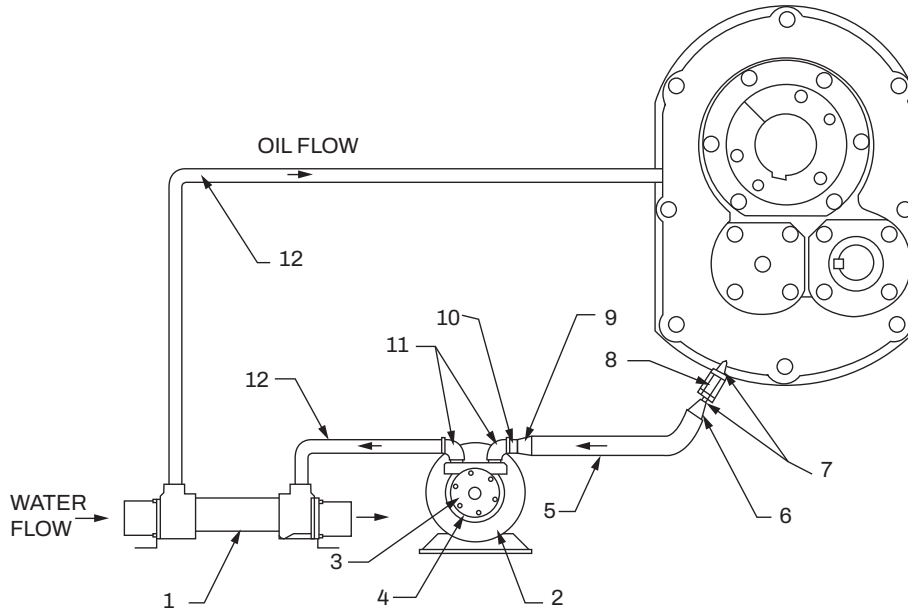

**Figure 1 - Cooling System for Torque-Arm Shaft Mounted Speed Reducer**

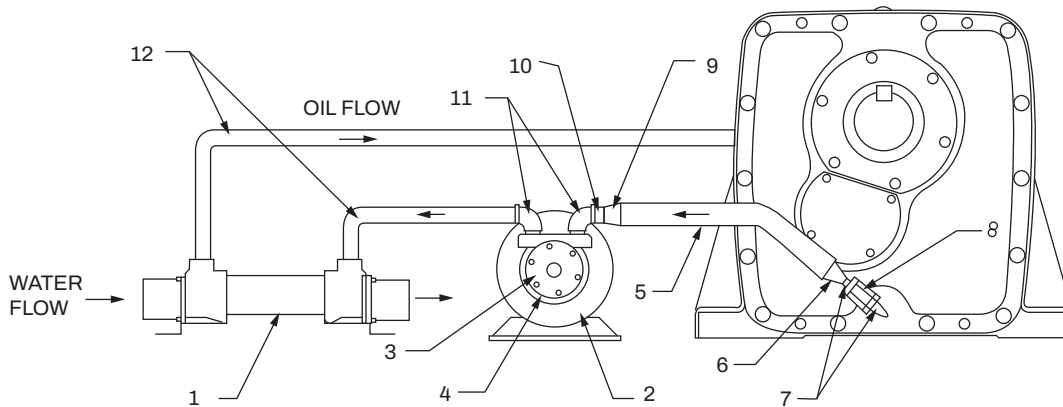

**Figure 2 - Cooling System for Maxum Concentric Speed Reducer**

Dodge Industrial, Inc.  
1061 Holland Road  
Simpsonville, SC 29681  
+1 864 297 4800

